

Kino

Designed by Kensaku Oshiro, 2020

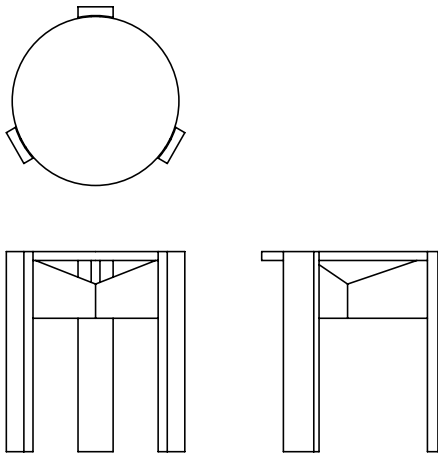



Kino Stool KN01-S1

A multi-purpose wood stool with rectangular legs and an inset circular top.

Depth	Width	Height
15.75"	15.75"	17.75"

Features

- Simple shapes and angular frame project a quiet and sophisticated visual language.
- Solid wood frame construction provides lasting durability.
- Resilient finishes provide longevity for vivid color, texture, and material protection within commercial applications.
- Frame wood available in a variety of finishes to meet a wide range of interior schemas and palettes.
- Seat surface available in solid wood or Forbo Linoleum for a multitude of colors, and textures.

Options

Tops available in Wood or Forbo Linoleum.
Clear or Stain Finishes.

Product Weight

8.3 lbs (3,8 kg)

Specifiable Materials

Wood (base, edge, top): Catalyzed Lacquer over Ash or Walnut, Stain → Memo Finishes Page

Colors and Finishes

Please see our Finishes Palette online to review actual swatches, specs, and to order samples → Memo Finishes Page

Content and Construction

Frame & Edge band: Solid wood
Top surface: Solid wood or Forbo over a plywood core
Glides: Molded nylon
Wood Finish: Catalyzed Lacquer, Stain

Weight Capacity

350 lbs (159 kg)

Testing

Memo products are designed to meet the requirements of the BIFMA test protocol and are also subject to additional performance requirements in order to withstand the rigors of commercial interiors.

For specific testing information, please contact us at info@memofurniture.com.

Environmental

For inquiries regarding Greenguard, MBDC, LEED, and LBC, please contact us at info@memofurniture.com.

Notes

Designed and Made in Seattle, Washington, USA.